

Vista

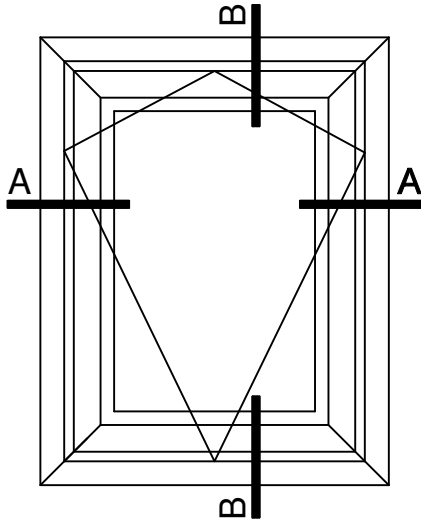

B-B Corte Vertical

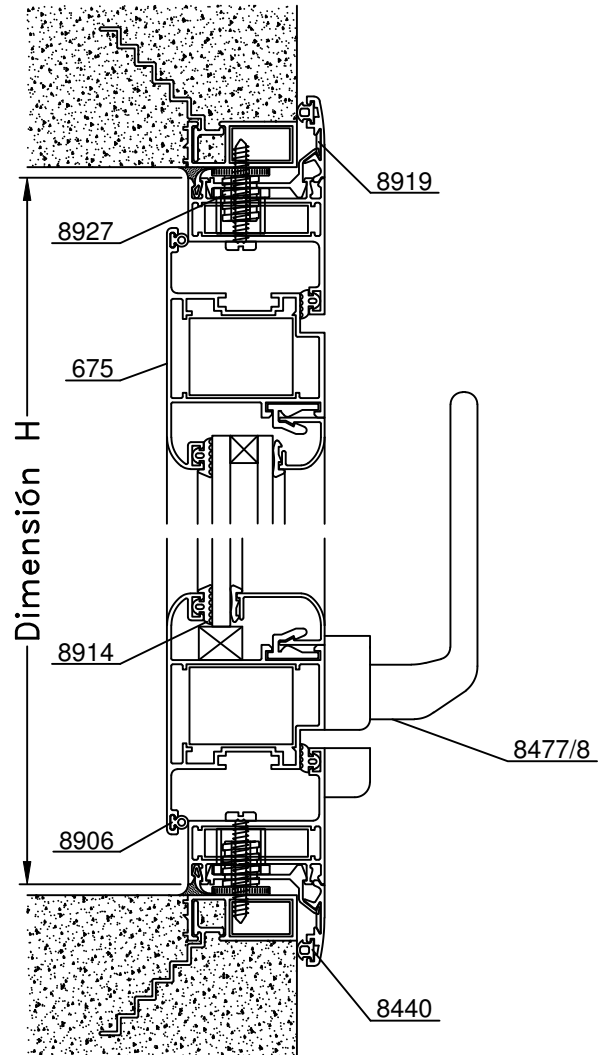

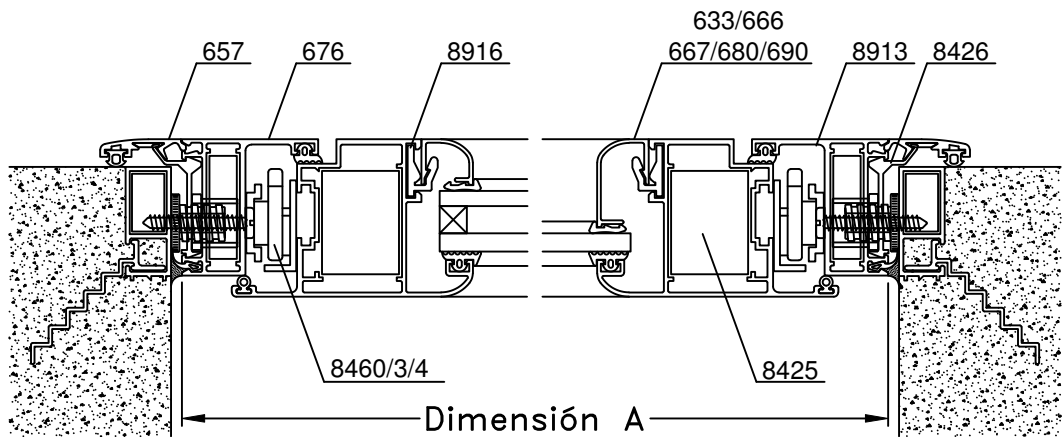

A-A Corte Horizontal













Escala 1:2.5
Tolerancia en Peso +/- 10%

20-01-12 **DELTA.51**

Dimensiones de Corte Ventana Desplazable						
Función	Código	Peso Kg/m	Forma	Cant.	Largo	Corte
Marco	676	0,72		2	A	45° 45°
				2	H	45° 45°
Hoja	675	1,07		2	A-32	45° 45°
				2	H-32	45° 45°
Contravidrio	Contravidrios Curvos	-	-	2	A-157	45° 45°
				2	H-157	45° 45°
	Contravidrios Rectos	-	-	2	A-157	90° 90°
				2	H-191	90° 90°

- Medidas en milímetros

- Dimensiones de Corte de Premarco y Contramarco, en página 55

Detalle de Accesorios Ventana Desplazable			
Código	Descripción	Forma	Cantidad
8423	Escuadra de Armado E-69		4 Unidades
8425	Escuadra Parante E-70		4 Unidades
8916	Clip Contravidrio T-96		s/m
8913	Burlete de Acristalamiento B-68		2A + 2H
8209	Cuña Chica		2A + 2H
8210	Cuña Mediana		
8211	Cuña Grande		
8906	Burlete AEL Europeo		2A + 2H
8914	Burlete de Hermeticidad B-67		2A + 2H
8477	Aldaba CP25		1 Unidad
8478	Aldaba Prima H-91		
8464	Tijera de Acero 259 mm. 50 kg. - 84°		1 Par
8460	Tijera de Acero 412 mm. 70 kg. - 90°		
8463	Tijera de Acero 558 mm. 74 kg. - 90°		
8471	Tijera de Acero 660 mm. 120 kg. - 20°		
8411	Tijera de Acero 262 mm. 37 kg. - 84°		
8412	Tijera de Acero 415 mm. 55 kg. - 90°		
8413	Tijera de Acero 567 mm. 75 kg. - 90°		
8414	Tijera de Acero 660 mm. 100 kg. - 20°		

s/m: según medida.

(a): En hojas de 900 mm o más de ancho se aconseja utilizar 2 aldabas de cierre por hoja.

H(*): Altura de Hoja.

Tijeras Cod.8460/8463/8464/8471 marca Cotsword.

Tijeras Cod.8411/8412/8413/8414 marca Storm.

Nota: En hojas de 1200 mm o más de alto se aconseja utilizar un limitador de apertura (Cód. 8479 o 8481)